



Pas Reform Vacuum waste container tank

For the clean, efficient collection and
removal of waste



Pas Reform
Hatchery Technologies



Vacuum waste container tank

Galvanised steel vacuum waste container tank with a capacity of 11 m³

Benefits

For the clean, efficient collection and removal of waste by vacuum from multiple locations in the hatchery. Waste collected in, for example, the candling and transfer room and the chick handling room is hygienically disposed of by vacuum pipes to a collection system located outside. This reduces any risk of cross contamination by transporting waste containers through various rooms inside the hatchery. Options include a galvanised steel vacuum waste container tank or a vacuum silo for each discharge directly into a waste container.

How it works

Vacuum waste container tank - Placed on a hook system frame, the tank allows the collection of up to 11m³ volume waste at one time. Once full, the container tank is lifted and moved away from the hatchery by a truck equipped with a cable pulley or hook system, for transportation to the waste disposal site. There the lid is unlocked and hydraulically opened for the safe, hygienic tipping and emptying of hatchery waste.

Vacuum silo - With the capacity for collecting 14m³ waste volume by means of vacuum, the silo is constructed of galvanised steel and manufactured for maximum durability. The silo lid is opened by means of a hydraulic pump, to release waste into a container for safe removal. A high gantry allows for a truck to pass completely underneath the waste silo for the clean, efficient discharge and transportation of waste.

Related products

- ▶ Candling & Take-out system
- ▶ Basket tipper
- ▶ Automatic separator
- ▶ Hatchery waste minimiser
- ▶ Dust filter for vacuum waste system
- ▶ Vacuum waste pump

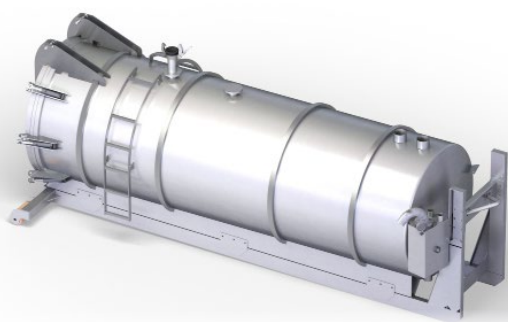

Technical Specifications

	Tank	Silo
Type		
Capacity	> 11 m ³	> 14 m ³
Filling degree	> 80%	> 80%
Dimensions (LxWxH)	> 6000 x 2160 x 2150 mm	> 4420 x 3215 x 10717 mm
Weight	> 2,500 kg	> 6,500 kg
Lid	> Standard diameter 1.6 metres, hydraulically operated, mechanically sealed	
Container	> Roller container, with a hook system as standard equipment	
Hydraulics	> Including cylinders and manually operated hydraulic pump unit.	
Connected values	> Waste input, 4", including quick release connector	
	> Vacuum input, 3", including quick release connector	
Safety	> The tank is equipped with a recoil valve which prevents waste from being pulled back into the vacuum pipe or to the vacuum pump.	
Material	> Galvanised steel	



Pas Reform
Hatchery Technologies

P.O. Box 2
7038 ZG Zeddam
The Netherlands

Phone +31 314 659 111
Fax +31 314 652 575
info@pasreform.com
www.pasreform.com